

Bosch iBooster Gen-1 Pinout

L = Large Pins

M = Medium Pins

S = Small Pins

CAVITY NUMBERING
Kammernummerierung

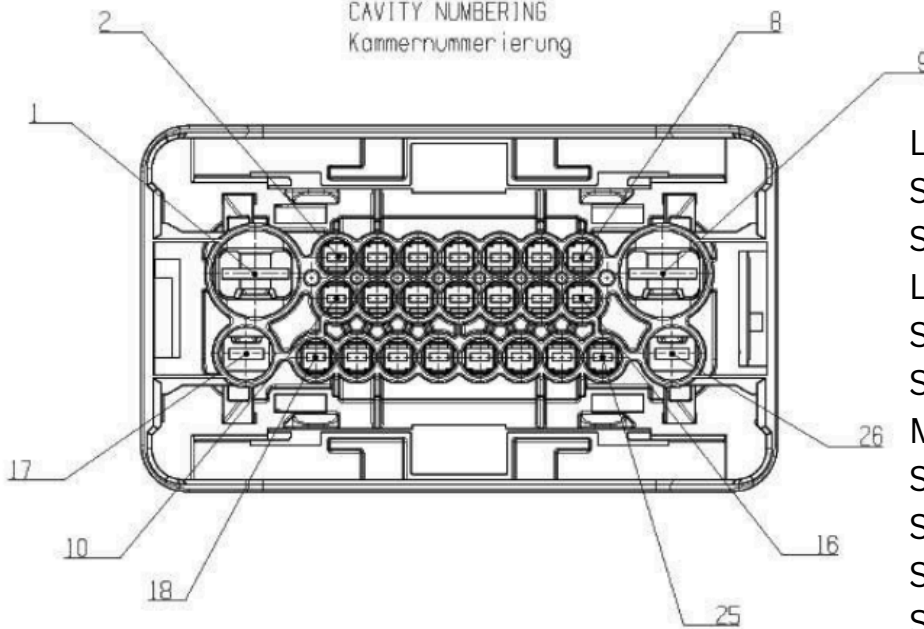

iBooster ECU

- L 1 - Always Hot Power (40A Fuse)
- S 2 - Pedal Travel Sensor - 1
- S 8 - Pedal Travel Sensor - 3
- L 9 - Chassis Ground
- S 10 - Yaw CAN-Low*
- S 16 - Vehicle CAN-High*
- M 17 - Always Hot Power (5A Fuse)
- S 18 - Yaw CAN-High*
- S 20 - Ignition Switched Power (5A Fuse)
- S 22 - Pedal Travel Sensor - 2
- S 23 - Pedal Travel Sensor - 4
- S 25 - Vehicle CAN-Low*

*Pins 10,16,18,25 are not needed
for basic operations

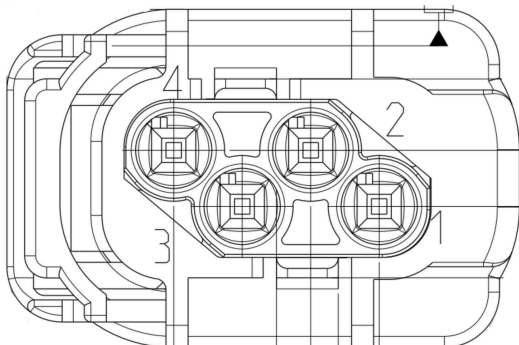

Pedal Travel Sensor

- 1 - iBooster ECU - 2
- 2 - iBooster ECU - 22
- 3 - iBooster ECU - 8
- 4 - iBooster ECU - 23